

## PERMIT APPLICATION

### ADVERTISING SIGNS / DISPLAY OF GOODS FOR SALE / OUTDOOR EATING FACILITIES

- BEECHWORTH & YACKANDANDAH ONLY



LOCAL LAW NO. 1 – STREETS & ROADS – Clause 20, 23 & 24			
Applicant Name			
Company Name			
Trading Name			
Address			
Telephone		Mobile	
Email Address		Fax	
Preferred method to receive permit: <input type="checkbox"/> Fax <input type="checkbox"/> Email <input type="checkbox"/> Post <input type="checkbox"/> Collect from ISC office			

Type of Permit:
<input type="checkbox"/> Advertising Sign – To place an advertising sign on a road – Clause 20
<input type="checkbox"/> Display of Goods for Sale – To place goods for sale or display on a road – Clause 23
<input type="checkbox"/> Outdoor Eating Facilities – To establish an outdoor eating facility on a road – Clause 24

Description of Sign/Goods/Outdoor Eating Facility (where possible, a photograph or drawing should be attached including colours and font):

Location of Sign/Goods/Outdoor Eating Facility (where possible, a photograph should be attached):

Date & Times the Sign/Goods/Outdoor Eating Facility is to be displayed

Important Requirements:
The applicant <b>MUST</b> hold current Public Liability Insurance for an amount not less than <b>TEN MILLION DOLLARS</b> (\$10,000,000) and must produce to Council evidence of such insurance. (Certificate of Currency)
The applicant must comply with any and all terms and conditions attached to the permit
The permit will only be valid for the days and time applied for
The permit may be revoked by Council for a breach of the permit conditions in accordance with Local Law No. 1
Non-refundable application fees apply on lodgement: <ul style="list-style-type: none"><li>• Advertising Signs <b>\$113.65</b></li><li>• Goods For Sale <b>\$113.65</b></li><li>• Outdoor Eating Facility <b>\$226.95</b></li></ul>

## PERMIT APPLICATION

### ADVERTISING SIGNS / DISPLAY OF GOODS FOR SALE / OUTDOOR EATING FACILITIES

- BEECHWORTH & YACKANDANDAH ONLY



#### Checklist for required items

(The application will be returned to the applicant if documentation is not attached)

- Copy of current Public Liability Insurance-no less than TEN MILLION DOLLARS
- Other relevant information (i.e. photographs or drawing including colours and font etc.)
- Payment of Application Fee

<b>\$113.65</b>	Advertising Sign
<b>\$113.65</b>	Display of Goods for Sale
<b>\$226.95</b>	Outdoor Eating Facilities

Permit Number: \_\_\_\_\_ Receipt Number: \_\_\_\_\_

Customer Service Officer: \_\_\_\_\_

Signature of Applicant: \_\_\_\_\_ Date: \_\_\_\_\_

#### **Privacy Policy Information**

*Personal information collected by Council is used for municipal purposes as specified in the Local Government Act 1989. The personal information will be used solely by Council for these purposes and/or directly related purposes. Council may disclose this information to other organisations if required by legislation. The applicant understands that the personal information provided is for the above purpose and that he/she may apply to Council for access to and/or amendments of the information. Any requests for access and/or correction should be made to Council's Privacy Officer.*

## PERMIT APPLICATION

### ADVERTISING SIGNS / DISPLAY OF GOODS FOR SALE / OUTDOOR EATING FACILITIES

- BEECHWORTH & YACKANDANDAH ONLY



#### Terms and Conditions

1. The maximum number of Advertising Signs/display of goods allowed under this permit is **one per every 4 metres of the applicant's frontage**. Where there is street furniture as well as A frames and display of goods, then **only 1 item per 4 metres of frontage** will be allowed.
2. The permit holder must ensure
  - a) Pedestrians have a clear access at all times to the entrance of the premises;
  - b) That the sign board/display or goods are exhibited away from the applicant's façade or if the items comply with Councils Trading Places policy they may be placed against the building line. Consideration must also be made to allow space for car doors to be freely opened where parallel parking is used.
  - c) The advertising sign or goods offered for sale must not be placed so as to obstruct driver vision at any intersection. In case whereby the sign or goods offered for sale are within 9 metres of an intersection then these articles must be made comply with the Trading Places document and placed against the building façade.
  - d) The sign board or structure supporting the goods offered for sale is of strong construction, and is maintained to the satisfaction of Council; and
  - e) That no notices, signs or other objects are attached to the sign board;
  - f) That no notices, signs or other objects are attached to or placed upon the merchandise other than a ticket (no longer than 200mm x 200mm) indicating the sale price;
  - g) The street furniture/'A' frame or display of goods maintains 1.5 metres clearance at all times from any other display/'A' frame or street furniture;
  - h) 2.8 metres of clear footpath, from the building façade, is maintained at all times in Beechworth. Traders are able to have items that have impervious sides against the building line for 1 metre only and then items may be placed from 2.8 metres out from the building façade out to the gutter; See last page for details.
  - i) That the signboard or goods offered for sale do not create a danger or nuisance to the public.
3. The permit - holder must ensure that the signboard
  - a) Is not more than 1200mm in height and not more than 750mm in width;
  - b) Has an extension of not more than 40mm;
  - c) Has no oscillating or moving parts; and
  - d) Contains a text which is not obscene, offensive or misleading
  - e) A frame signs must comply with heritage requirements where applicable.
4. The permit holder shall at all times during the agreed term, be the holder of a current Public Liability Policy of Insurance ("The Public Liability Policy) in respect of the activities specified herein in the name of the permit holder providing coverage for a minimum sum of \$10 million. The Public Liability Policy shall be affected with an insurer approved by the Council
5. All signs or advertising items must only be placed where items or goods are for sale, no remote signage is permitted, other than in a form approved under the tourism signage guidelines.

**PERMIT APPLICATION**

**ADVERTISING SIGNS / DISPLAY OF GOODS FOR SALE / OUTDOOR EATING FACILITIES**

- BEECHWORTH & YACKANDANDAH ONLY

**Beechworth & Yackandandah Footpath Trading Requirements**

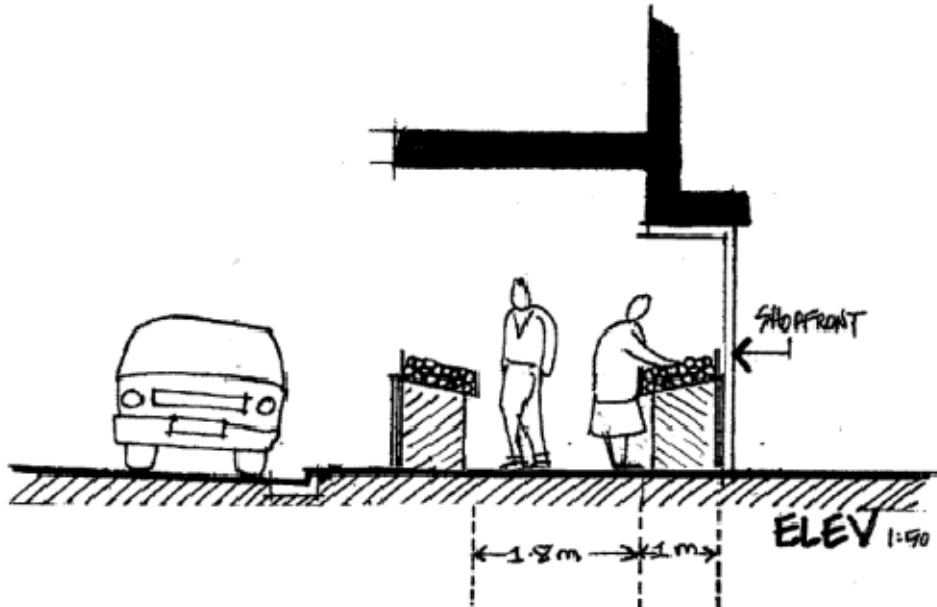

In Beechworth & Yackandandah permit holders are permitted to place items against the building façade, the items placed against the building must have impervious or solid sides to prevent the item becoming a trip hazard. Tables & chairs, clothes racks, 'A' frame signs with open sides and other similar items without solid sides are not to be placed against the façade. The permit holder may then place other items 2.8m from the shopfront or façade, these items can include tables and chairs and do not require solid sides or edges.

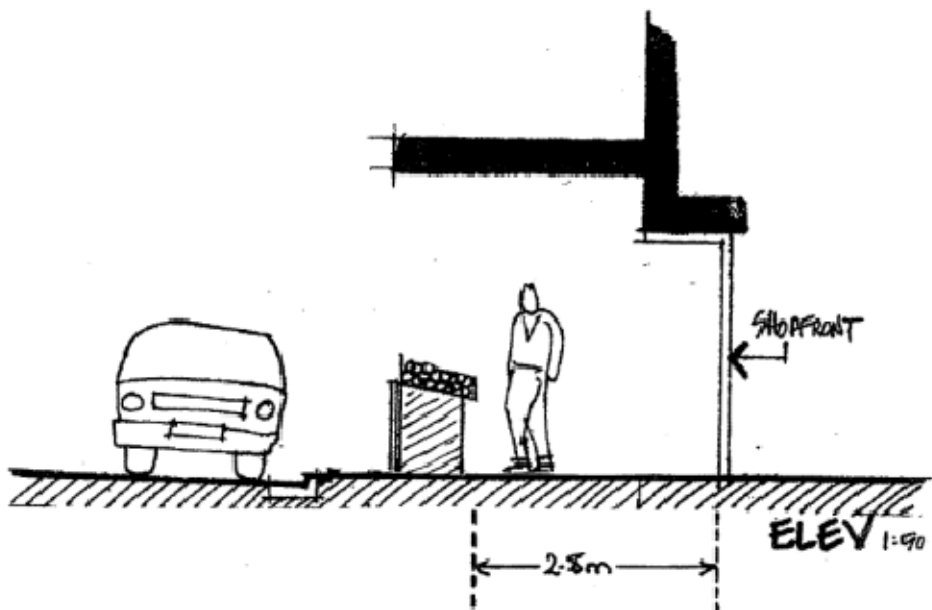

Permit holders that choose to have items placed away from the shopfront or facade are not required to comply with the impervious side or edges requirements on signage or displays and tables and chairs. These items must be placed 2.8 metres from the building façade.